

物件名			
<h1>ファミリーDAN</h1>			
種別	マンション	総戸数	38 戸
構造	鉄筋コンクリート造 6 階		
完成時期	平成 9 年 月		

号室	間取り	空状態	月額費用				契約時費用			
			家賃	共益費	水道代 実費	駐輪場代 無料	駐車場代 6,600円(税込)	礼金	敷金	火災保険料 20,000円/2年
※ 費用・その他条件については最新の空室情報にてご確認をお願いします。										

物件所在地	〒 525-0048 滋賀県草津市追分南2丁目1-5		
交通機関	JRびわこ 線	南草津 駅	16 分
周辺環境	フレンドマート:160m / 近江草津病院:300m		
最寄施設	志津南小学校:2100m / 高穂中学校:750m		

契約期間	2年	更新時費用		
解約予告	2ヶ月前	契約更新料	事務手数料	火災保険料
		0円	0円	20,000円

【その他入居条件】
-----------

設備	電気	ガス	水道	キッチン	トイレ	風呂	給湯
	関西電力	都市ガス	公営	3口システムキッチン	水洗	有	ガス給湯
	ベランダ	洗濯機設置	洗面台	エレベーター	オートロック	BSアンテナ	インターネット
	有南	室内可	有	有	***	有	光ファイバー NTT
	エアコン	床	宅配ボックス	照明器具			
	***	フローリング ウッドタイル 畳	***	***			
駐輪場		駐車場		火災保険			
自転車または原付 1人1台		6,600円(税込)/月 下記備考欄参照		20,000円/2年			

【備考】  
第1駐車場、第2駐車場:6,600円(税込)  
第1駐車場は1室1台のみ

### 3口コンロカウンター付きシステムキッチン / テレビモニターフォン

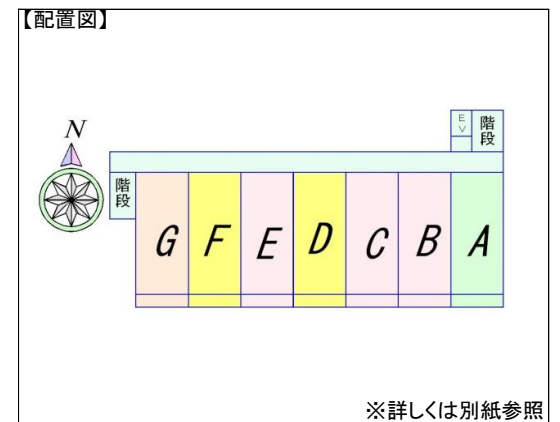

必要書類	契約者	住民票/在職証明/源泉・納税証明/顔写真/身分証明書
	保証人	保証人1名/印鑑証明
家賃支払	口座引落(滋賀銀行のみ)、引落手数料無し	
電気業者	関西電力/滋賀営業所 0800-777-8810 (事前に使用開始日、登録番号を連絡)	
水道業者	2ヶ月に1回管理会社にて検針の上、請求(賃料と共に口座引落)	
ガス業者	ヤマキ/0120-172-123 (事前に電話予約の上、立会い開栓)	
ネット業者	NTT	

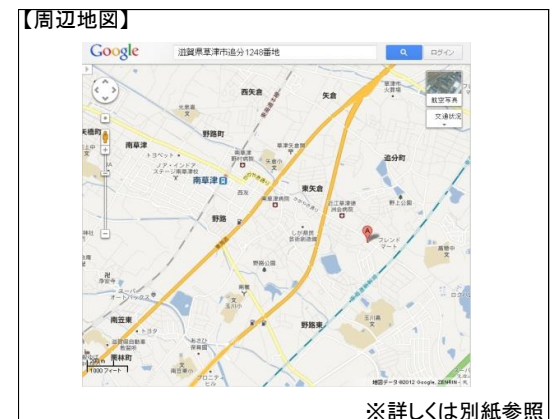
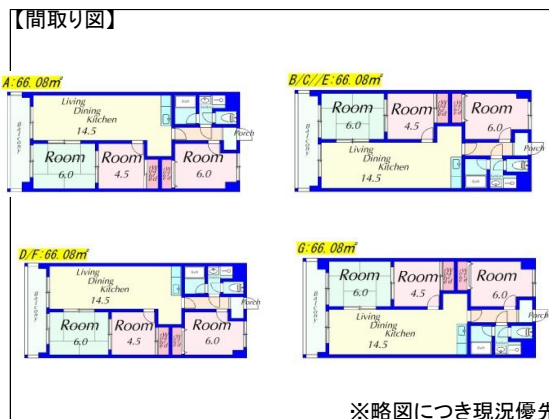

会社名 \_\_\_\_\_

よろしくお願いたします。



A: 66.08m<sup>2</sup>



B/C/E: 66.08m<sup>2</sup>

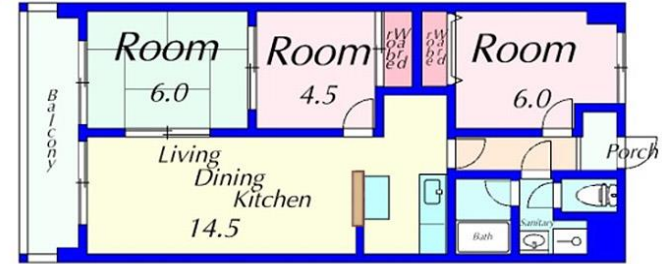

D/F: 66.08m<sup>2</sup>



G: 66.08m<sup>2</sup>

